

5.95m

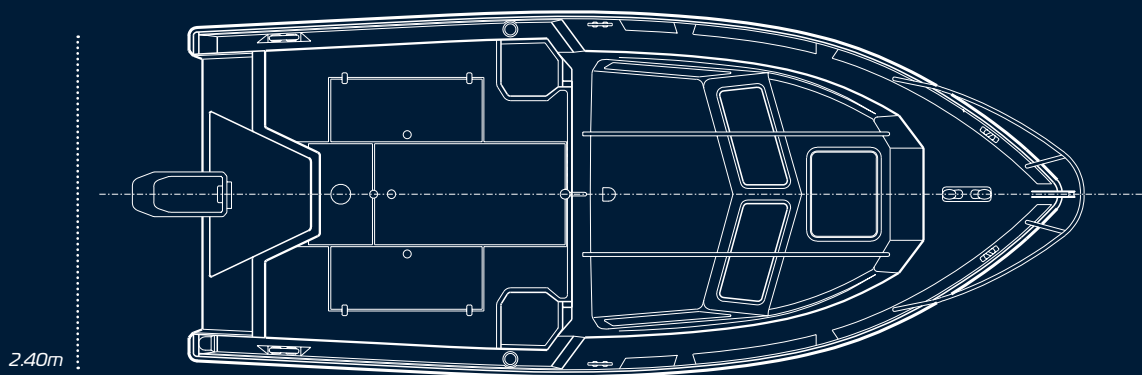

2.40m

Length	19'6"	5.95m	Performance Indicator	30hp	12kts	Engine Type	Single Outboard
Beam	7'10"	2.40m		60hp	18kts	Outboard Shaft Type	Long shaft
Displacement	2030lbs	925kg		80hp	23kts	Recommended hp Range	30hp 80hp
Self Draining Cockpit	y					Max Engine hp	80hp
.....			Optimum Design Speed	15kts		
Payload			Max Design Speed	23kts		Fuel Capacity	3x25 ltrs
Max Persons	7						135 ltrs (optional)
Max Load	750kg					Water Capacity	16 ltrs (optional)
RCD Category	Cat C						

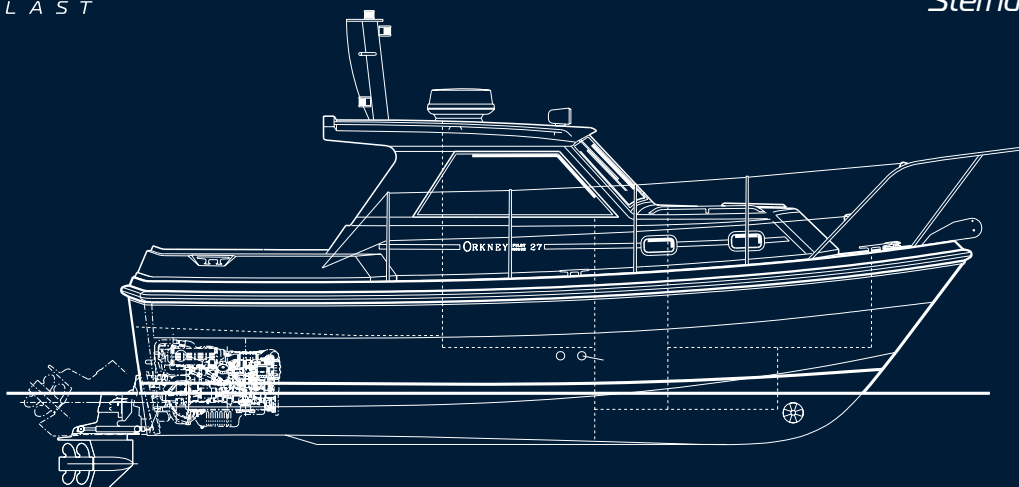

7.60m

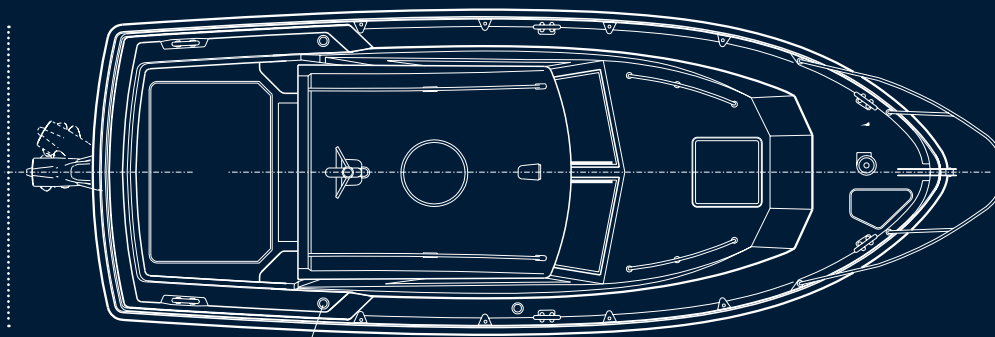

2.80m

Length	24'8"	7.60m	Performance Indicator	190hp	23kts	Engine Type	Diesel Inboard Sterndrive
Beam	9'2"	2.80m		220hp	25kts		
Displacement	7500lbs	3400kg		250hp	27kts	Recommended hp Range	230hp 250hp (Single)
Self Draining Cockpit	y			300hp (Twin)	27kts	Max Engine hp	300 (Twin) 2 x 150hp
<hr/>							
Payload			Optimum Design Speed	17kts		Fuel Capacity	365ltrs standard (Single)
Max Persons	10		Max Design Speed	27kts		Water Capacity	70ltrs
Max Load	1400kg						
RCD Category	Cat B						

PILOTHOUSE 25

Outboard Version

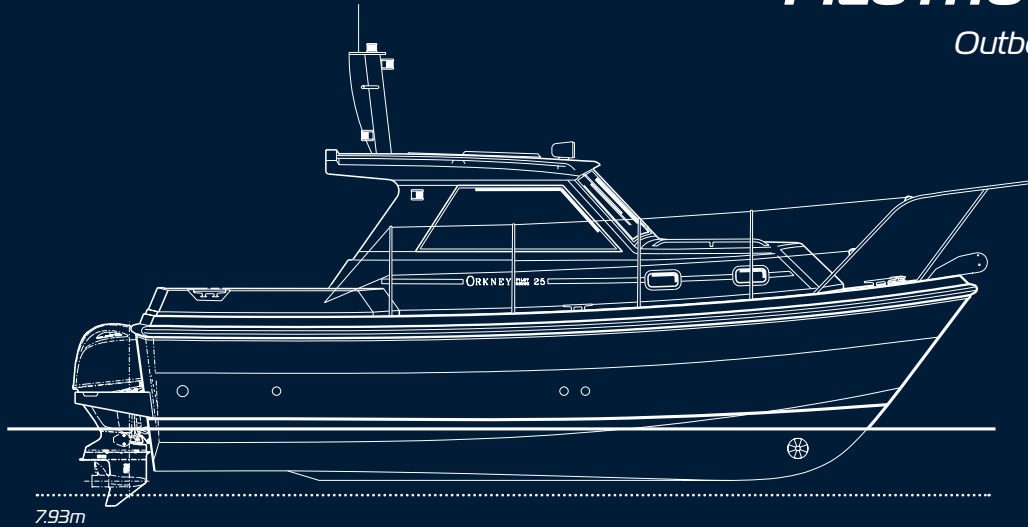

7.93m

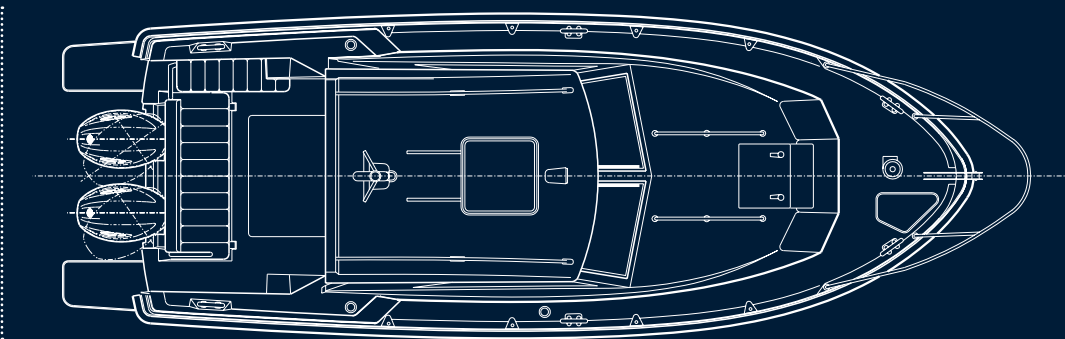

2.80m

Length	24'8"	7.93m	Performance Indicator	220hp	25kts	Engine Type	Single or Twin Outboard
Beam	9'2"	2.80m		240hp	27kts	Recommended hp Range	225hp 280hp
Self Draining Cockpit	y			300hp (Twin)	27kts	Max Engine hp	250hp (Single) 2 x 150hp (Twin)
<hr/>							
Payload			Optimum Design Speed	17kts		Fuel Capacity	365ltrs standard (Single)
Max Persons	10		Max Design Speed	27kts		Water Capacity	70ltrs
RCD Category	Cat B						

** Preliminary details only pending final design

PILOTHOUSE 27

Sterndrive Version

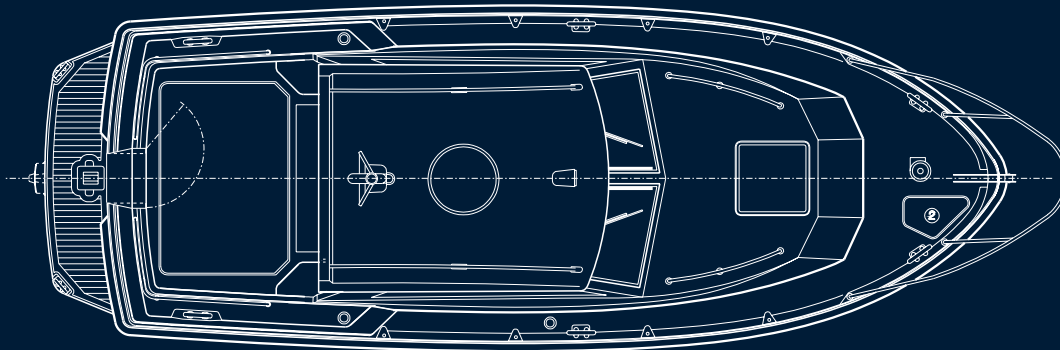

Length	26'8"	7.93m	Performance Indicator	250hp	27kts	Engine Type	Diesel inboard Sterndrive
Beam	9'2"	2.80m		300hp (Twin)	27kts	Recommended hp Range	250hp 280hp
Displacement	7940lbs	3600kg				Max Engine hp	280hp (Single)
Self Draining Cockpit	y						300hp (Twin) 2 x 150hp
			Optimum Design Speed	17kts			
			Max Design Speed	27kts			
Payload						Fuel Capacity	365ltrs standard (Single)
Max Persons	10					Water Capacity	70ltrs
Max Load	1400kg						
RCD Category	Cat B						

PILOTHOUSE 27

Outboard Version

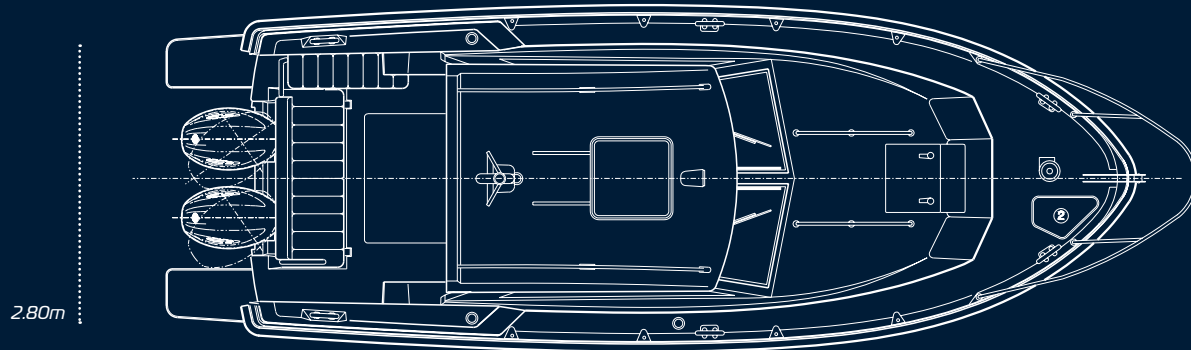

Length	26'8"	7.93m	Performance Indicator	250hp(Single) 27kts	Engine Type	Single or Twin outboard
Beam	9'2"	2.80m		300hp (Twin) 27kts		
Self Draining Cockpit	y				Recommended hp Range	250hp 300hp
					Max Engine hp	300hp (Single) 300hp (Twin) 2 x 150hp
Payload			Optimum Design Speed	17kts		
Max Persons	10		Max Design Speed	27kts		
RCD Category	Cat B				Fuel Capacity	365ltrs standard (Single)
					Water Capacity	70ltrs

** Preliminary details only pending final design



PILOTHOUSE RANGE

	PILOTHOUSE 20 OUTBOARD		PILOTHOUSE 25 STERNDRIVE		PILOTHOUSE 25 OUTBOARD **		PILOTHOUSE 27 STERNDRIVE	
Length	19'6"	5.95m	24'8"	7.60m	24'8"	7.93m	26'8"	7.93m
Beam	7'10"	2.40m	9'2"	2.80m	9'2"	2.80m	9'2"	2.80m
Displacement (note 1)	2030lbs	925kg	7500lbs	3400kg			7940lbs	3600kg
Self Draining Cockpit (note 2)	y		y		y		y	
Payload (note 3)								
Max Persons	7		10		10		10	
Max Load	750kg		1400kg		TBC		1400kg	
CE (RCD) Category	Cat C		Cat B		Cat B		Cat B	
UKCA (RCR) Category	Cat C		Cat B		Cat B		Cat B	
Performance Indicator (note 4)	30hp	12kts	220hp	25kts	250hp	25kts	250hp	23kts
	60hp	18kts	250hp	27kts	280hp	27kts	280hp	27kts
	80hp	23kts	300hp (TZ)	27kts	300hp (TO)	27kts	300hp (TZ)	27kts
Engine Type (note 5)	SO		SZ / TZ		SO/TO		SZ / TZ	
Outboard Shaft Type	Long shaft		n/a		Extra Long Shaft		n/a	
Recommended hp Range	30hp	80hp	170hp	250hp	225hp	300hp	230hp	280hp
Max Engine hp	80hp (SO)		250hp(SZ)	300hp (TZ)	250hp(SO) 2x150hp (TO)		280hp (SZ)	300hp (TZ)
Optimum Design Speed (note 6)	15kts		17kts		17kts		17kts	
Max Design Speed (note 7)	23kts		27kts		27kts		27kts	
Fuel Capacity (note 8)	3x25 (SO)	135ltrs (opt)	365ltrs		365ltrs		365ltrs (SZ) 2x227ltrs (opt)	
Holding Tank	25ltrs (optional)		43ltrs		43ltrs		43ltrs	
Water Capacity	16 ltrs (optional)		70ltrs		70ltrs		70ltrs	

**Preliminary details only pending final design

Please Note: All Weights, Measurements and Performance indicators are approximate. Dimensions and weights do not include engines or accessories, except where otherwise indicated. Drawings and illustrations are not to scale and they may show boats fitted with optional equipment. For specifications and full details of accessories, please see our current price list.

PILOTHOUSE 27 OUTBOARD**

26'8" 7.93m

9'2" 2.80m

V

10

TBC

Cat B

Cat B

250hp 23kts

300hp 27kts

300hp (TO) 27kts

SO / TO

Extra Long Shaft

250hp 280hp

300hp (SO) 2x150hp (TO)

17kts

27kts

365ltrs

43ltrs

70ltrs

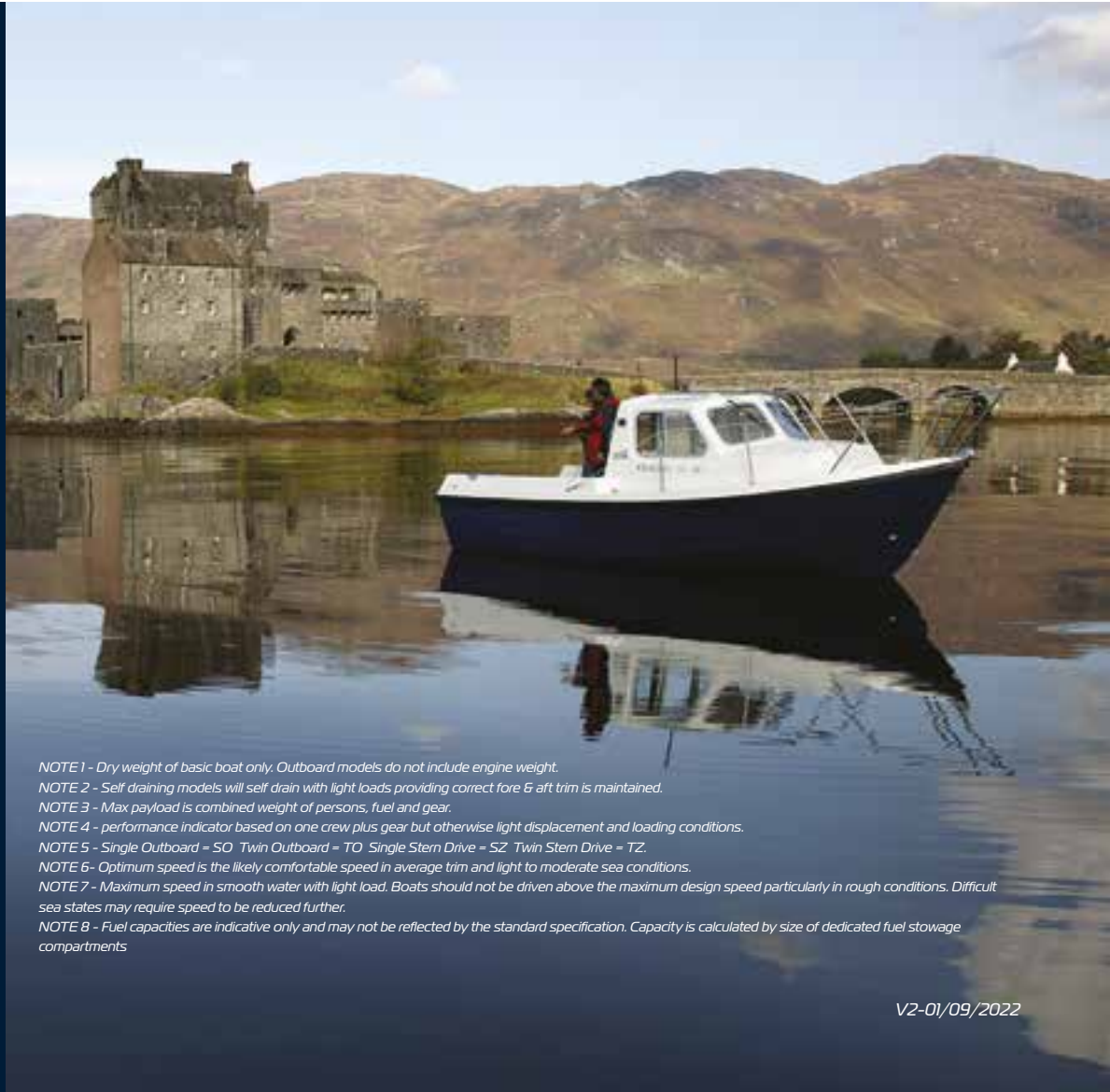

NOTE 1 - Dry weight of basic boat only. Outboard models do not include engine weight.

NOTE 2 - Self draining models will self drain with light loads providing correct fore & aft trim is maintained.

NOTE 3 - Max payload is combined weight of persons, fuel and gear.

NOTE 4 - performance indicator based on one crew plus gear but otherwise light displacement and loading conditions.

NOTE 5 - Single Outboard = SO Twin Outboard = TO Single Stern Drive = SZ Twin Stern Drive = TZ.

NOTE 6 - Optimum speed is the likely comfortable speed in average trim and light to moderate sea conditions.

NOTE 7 - Maximum speed in smooth water with light load. Boats should not be driven above the maximum design speed particularly in rough conditions. Difficult sea states may require speed to be reduced further.

NOTE 8 - Fuel capacities are indicative only and may not be reflected by the standard specification. Capacity is calculated by size of dedicated fuel stowage compartments

V2-01/09/2022

WORK BOATS & SPECIALS

Our standard designs are intended for leisure use only and may not be suitable for commercial, intensive or continuous hard use without some modifications being made. We can build specialised workboats on most of our hulls. To ensure you get the right boat for the job please consult us directly, or your local Orkney dealership, for advice regarding the suitability for your application where we will be happy to assist you.

SPEEDS

Our boats are designed to perform well with relatively small engines. This is achieved by having specially designed hulls with a moderate amount of V in the sections combined with high strength to low weight construction methods.

With fairly light payloads the speeds indicated in our brochures will be delivered in smooth water using the recommended engines; with increased loads, lower speeds may result. Our boats should be driven at lower speeds in heavy trim when encountering rough conditions because higher weights and higher speeds generate disproportionately large loads on the hulls. Consequently our warranty does not cover boats using bigger engines

than we recommend or boats that have been used at speeds greater than advised in our literature and/or owners manuals.

Boating is still largely an unregulated pastime in the UK. At Orkney Boats we strongly encourage owners to use their boats in a seamanlike manner and show full consideration to others both afloat and offshore. If you have not been boating before, or would like to brush up your knowledge on boat handling and the care and maintenance of your boat, we recommend that you consider one or more of the wide range of available courses, many of which are RYA approved. Please contact your dealer who will be able to provide details.

TERMS OF BUSINESS

A copy of our terms of business and details on warranty conditions are available on request.

Customers should note that Orkney Boats are hand built in modest volumes. Whilst great care is taken during all the building stages to ensure structural integrity, the nature of the GRP process and other techniques involved may occasionally result in minor surface blemishes and/or minor variations in fit and finish.

These type of small imperfections have no impact on the strength or seaworthiness of our boats; they are not considered to be faults and are not covered by our warranty. Small gel blemishes can be dealt with by using the repair kit provided with each new boat and other help can be found in the Owner's Manual.

All weights, measurements and performance indicators given are approximate. Dimensions and weights do not include engines or accessories, except where otherwise indicated. Drawings and illustrations are not drawn to scale and they may show boats fitted with optional equipment. For specifications and full details of accessories, please see our current price list.

We are constantly seeking ways to improve our products and we therefore reserve the right to change specifications as necessary. This does not affect any quotation given subject to our general terms and conditions.

Prices include VAT at the current rate. If VAT rates are changed, Orkney Boats Limited will charge at the applicable rate.

EEOE